

4

3

2

1

REVISION HISTORY			
REV.	DESCRIPTION	DATE	DRAWN BY
1	ORIGINAL PRINT	10/10/2019	N. LAWRENCE

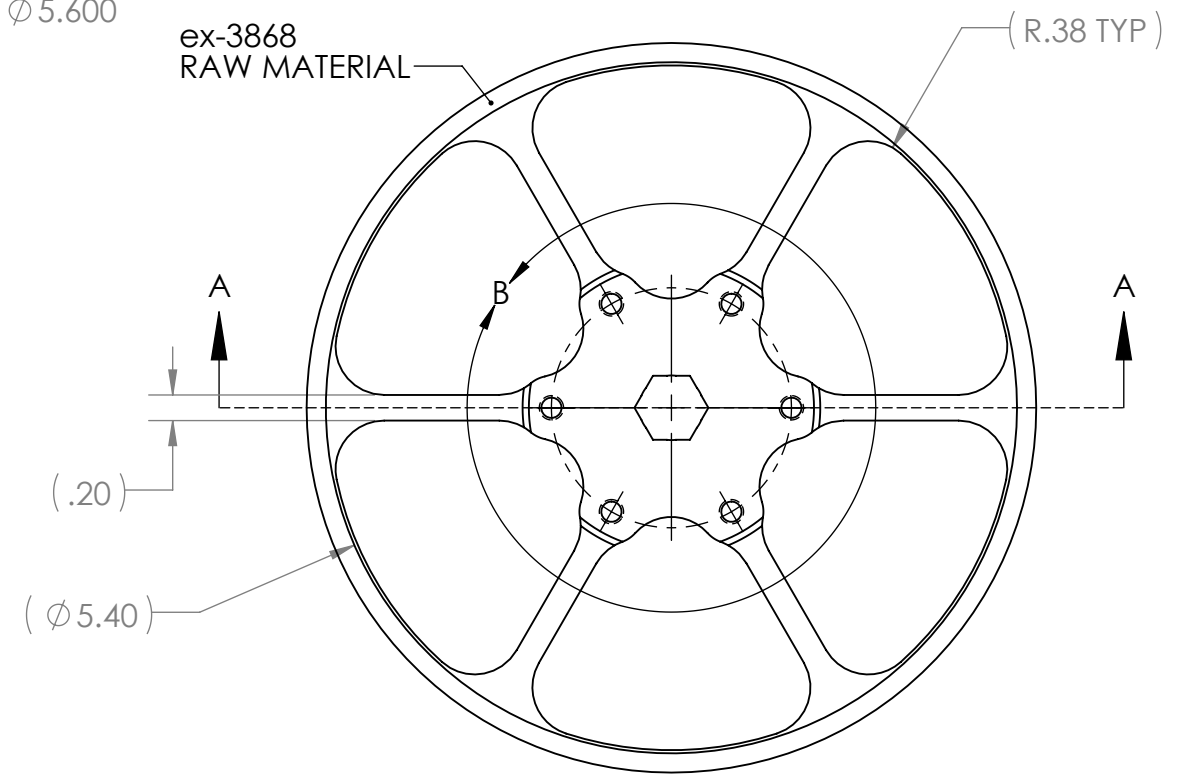
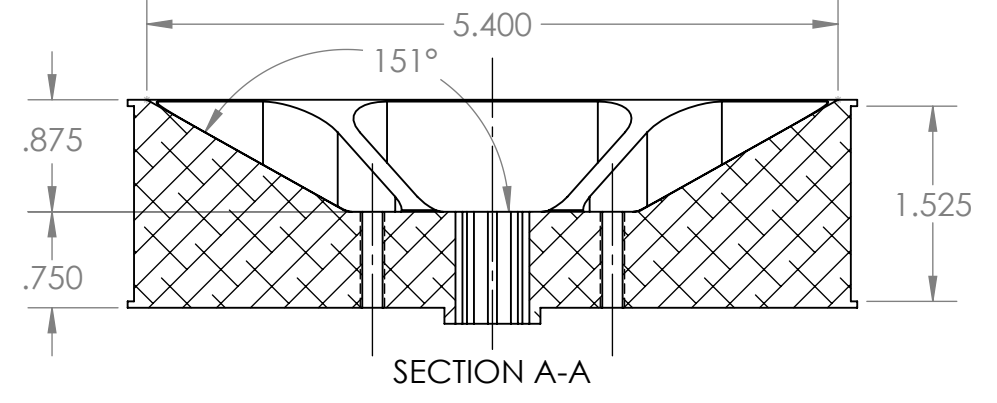
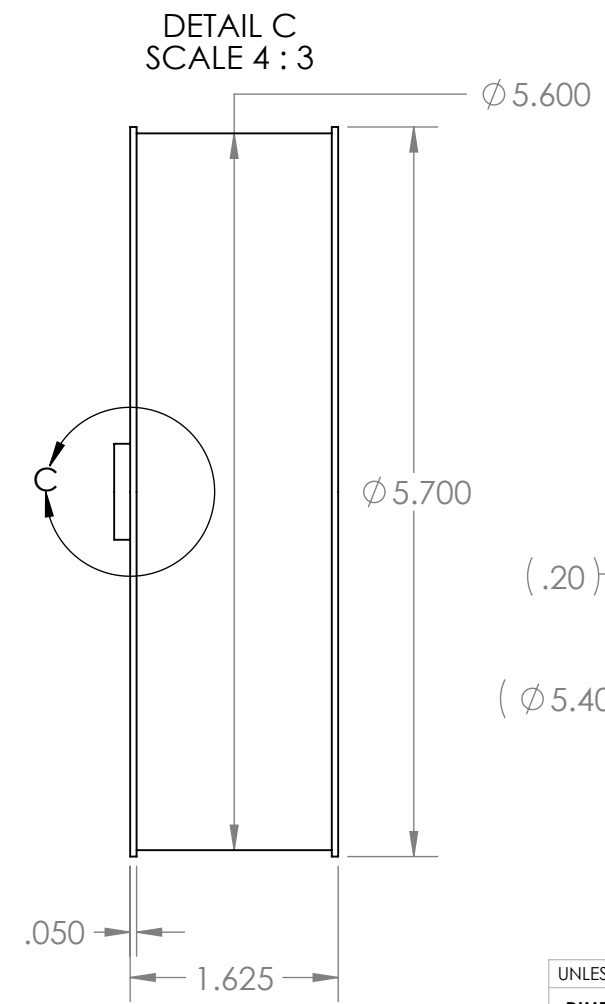
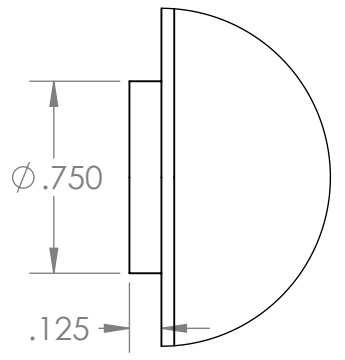
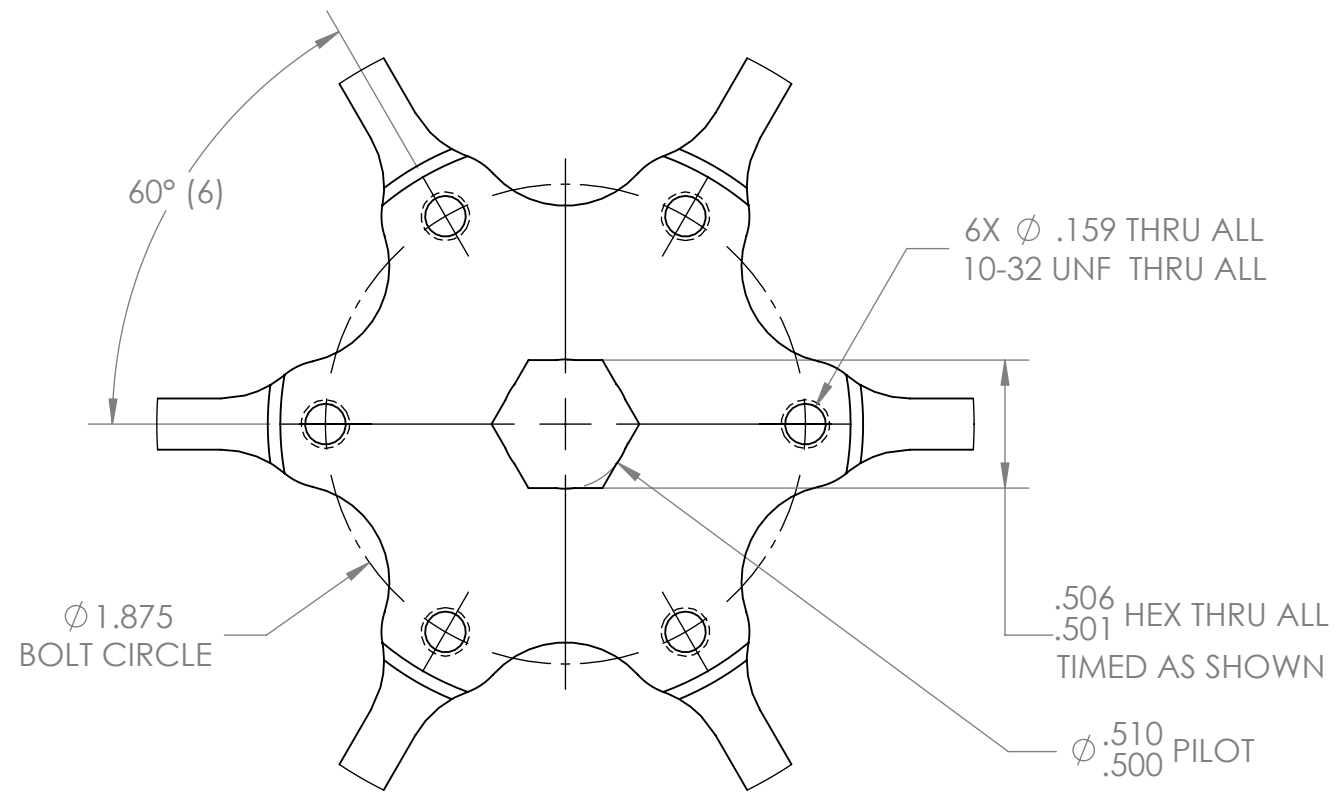

DETAIL B
SCALE 4 : 3

DETAIL C
SCALE 4 : 3

*** SEE CAD FOR ADDITIONAL TOOLPATH INFO***

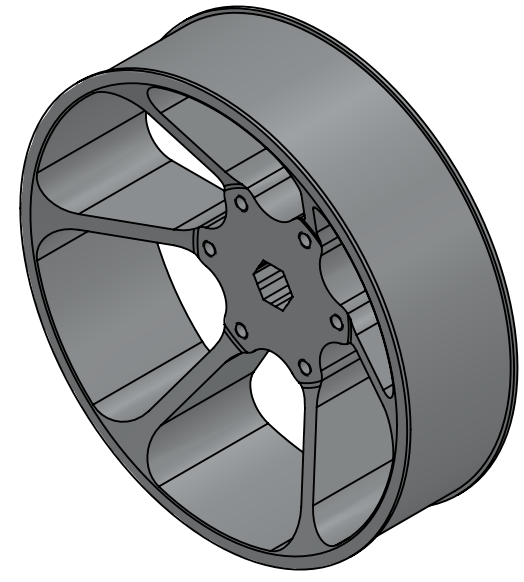

UNLESS OTHERWISE SPECIFIED:		COMMENTS:				
DIMENSIONS ARE IN INCHES		DUAL DIMENSIONS ARE IN MILLIMETERS.				
TOLERANCES:		BREAK ALL SHARP EDGES.		SIZE	DWG. NO.	REV
FRACTIONAL	±1/16			B	am-4177	1
ANGULAR: MACH	±1°			SCALE: 2:3	SHEET 1 OF 1	
ANGULAR: BEND	±5°					
ONE PLACE DECIMAL	±0.1					
TWO PLACE DECIMAL	±0.01					
THREE PLACE DECIMAL	±0.005					
FOUR PLACE DECIMAL	±0.0005					
MATERIAL	6061-T6 AL	CHECKED	NAME	DATE		
FINISH	TUMBLER	ENG APPR.	NM	10/10/19		
		MFG APPR.				
		Q.A.				

4

3

2

1