

REVISION HISTORY			
REV.	DESCRIPTION	DATE	DRAWN BY
1	ORIGINAL PRINT	2/15/2021	N. LAWRENCE

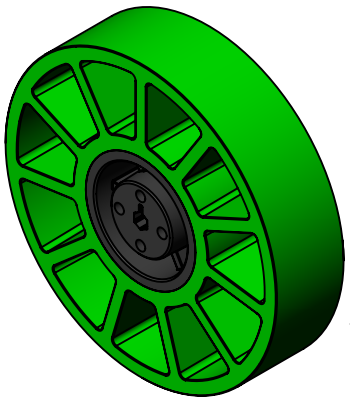
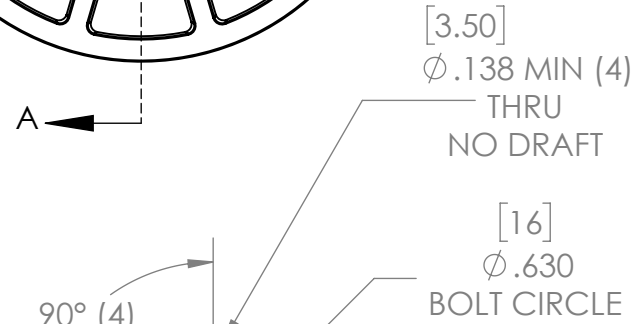
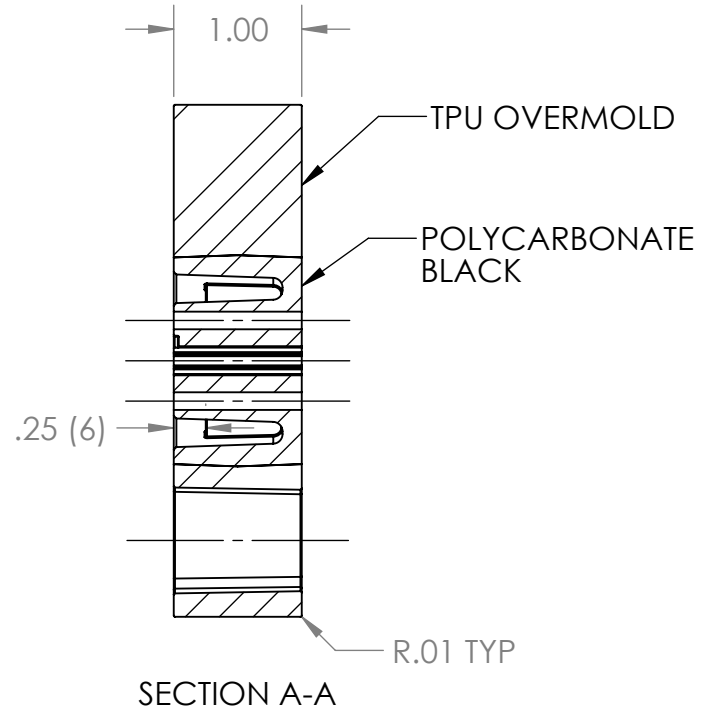
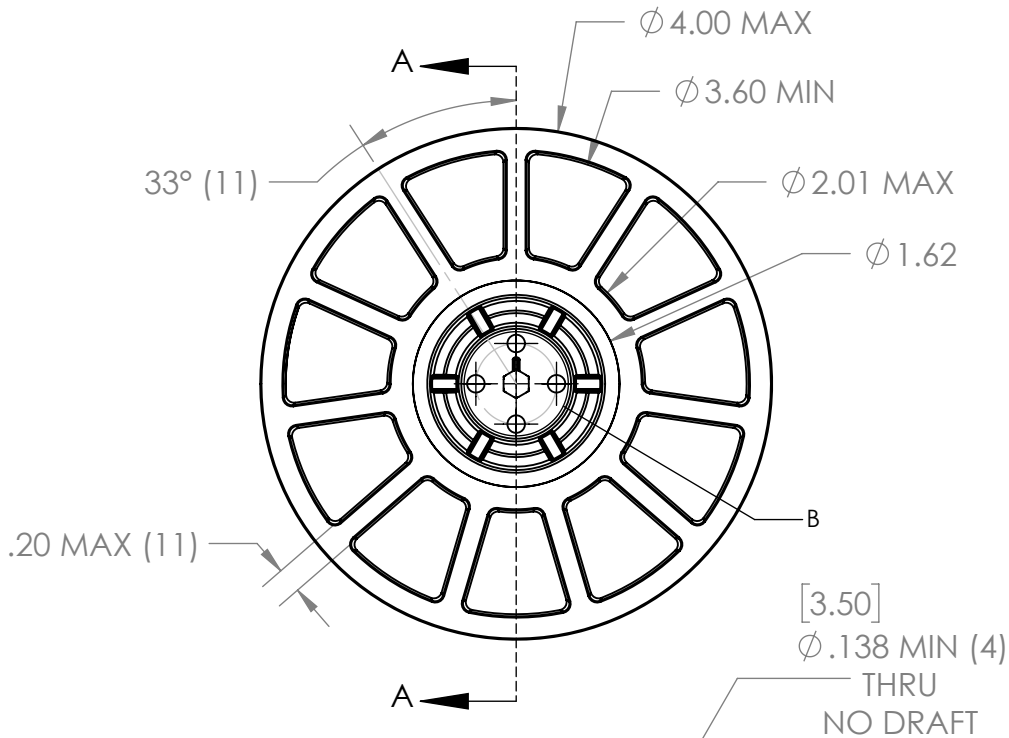

[5]  
 .197 MIN  
 HEX THRU  
 TIMED AS SHOWN  
 NO DRAFT

DETAIL B  
 SCALE 2 : 1.5

\*\*\* SEE CAD FOR ADDITIONAL TOOLPATH INFO\*\*\*

UNLESS OTHERWISE SPECIFIED:		COMMENTS:	
<b>DIMENSIONS ARE IN INCHES</b>		DUAL DIMENSIONS ARE IN MILLIMETERS.	
TOLERANCES:		BREAK ALL SHARP EDGES.	
FRACTIONAL	±1/16		
ANGULAR: MACH	±1°		
ANGULAR: BEND	±5°		
ONE PLACE DECIMAL	±0.1		
TWO PLACE DECIMAL	±0.01		
THREE PLACE DECIMAL	±0.005		
FOUR PLACE DECIMAL	±0.0005		
MATERIAL	PC CORE TPU OVERMOLD	CHECKED	NAME NM
FINISH	DEBURRED	ENG APPR.	DATE 2/19/21
DO NOT SCALE DRAWING		MFG APPR.	
		Q.A.	



TITLE:  
**4IN 5mm HEX BORE  
 COMPLIANT WHEEL**

SIZE <b>A</b>	DWG. NO. am-4538	REV 1
------------------	---------------------	----------

SCALE: 1:1.5 SHEET 1 OF 1