



Ai-M62-M2-I-Kit Specification

Version V1.1.0

Copyright ©2023

Document resume

Version	Date	Develop/revise content	Edition	Approve
V1.0.0	2023.3.31	First Edition	Cong Chen	Hong Xu

Content

1. Product Overview	4
1.1. Characteristic	5
2. Main parameters	6
2.1. Power selection	6
2.2. Static electricity requirement	6
2.3. Electrical characteristic	7
2.4. Wi-Fi RF Performance	7
2.5. BLE RF Performance	8
2.6. Power consumption	8
3. Appearance Dimensions	9
4. Description of the indicator light and the key button	10
5. Pin definition	11
6. Schematic-diagram	14
7. Product packing information	15
8. Contact us	15
Disclaimer and copyright notice	16
Notice	16

1. Product Overview

The Ai-M62-M2-I-Kit is a development board designed for the Ai-M62-M2-I module. Ai-M62-M2-I is a Wi-Fi 6 + BLE 5.3 module developed by Shenzhen Ai-Thinker Technology Co., Ltd. The module is equipped with BL616 chip as the core processor, supports Wi-Fi 802.11b/g/n/ax protocol and BLE protocol, and supports Thread protocol. The BL616 system contains a low-power 32-bit RISC-V CPU with floating point cells, DSP units, cache, and memory, up to 320M.

Ai-M62-M2-I module has rich peripheral interfaces, including Audio Codec, USB2.0, SDU, SD / MMC (SDH), SPI, UART, I2C, I2S, PWM, GPDAC, GPADC, ACOMP and GPIO. It can be widely used in audio and video multimedia, Internet of Things (IoT), mobile devices, wearable electronic devices, smart home and other fields.

Ai-M62-M2-I module Sec Eng module supports AES / SHA / PKA / TRNG and other functions, supports mirror encryption and signature startup, to meet the needs of various security applications in the field of the Internet of Things.

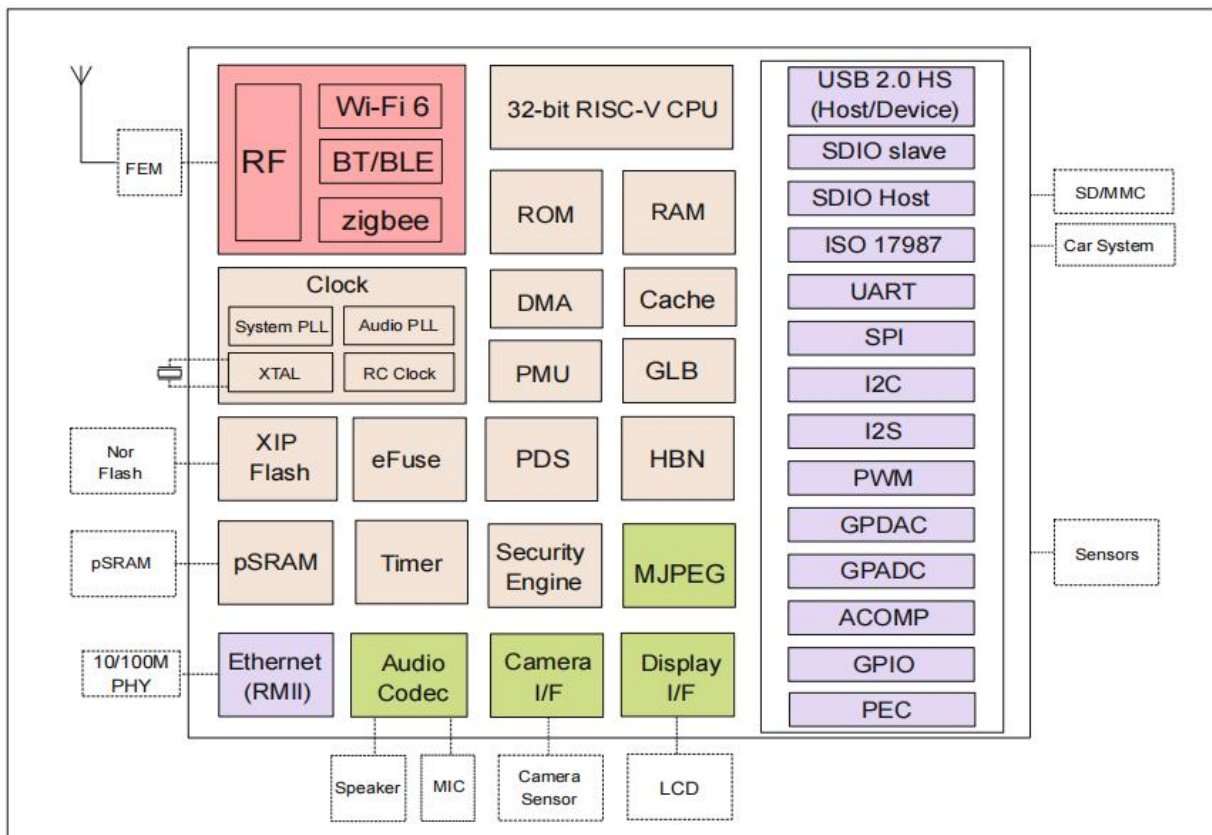

Figure 1 Main chip block diagram

1.1. Characteristic

- The package is DIP-30
- Support 2.4GHz frequency
- Support IEEE 802.11 b/g/n/ax
- Support BLE5.3
- Support Thread
- Support Wi-Fi/BLE/Thread coexistence
- Wi-Fi security support WPS/WEP/WPA/WPA2/WPA3
- Support 20/40MHz bandwidth , 1T1R, speed up to 229.4 Mbps
- Support STA、SoftAP、STA+SoftAP and sniffer mode
- A 32-bit RISC-V CPU with FPU and DSP, with a maximum main frequency of up to 320M
- 532KB SRAM, 128KB ROM, 4Kb eFuse
- Support Audio Codec、USB2.0、SDU、SD/MMC(SDH)、SPI、UART、I2C、I2S、PWM、GPDAC、GPADC、ACOMP and GPIO,etc.
- Integrated RF Balun、PA/LNA
- Support safe startup; safe debugging
- Support XIP QSPI On-The-Fly AES deciphering (OTFAD)
- Support TrustZone
- Support AES-CBC/CCM/GCM/XTS mode
- Support MD5、SHA-1/224/256/384/512
- Support TRNG (True random number generator)
- Support PKA for RSA / ECC (Public key accelerator)
- Support the Wi-Fi fast connection for BLE
- General AT instructions can be quickly used
- Support for secondary development, with integrated Windows, Linux development environments

2. Main parameters

Table 1 Description of the main parameters

Development board model	Ai-M62-M2-I-Kit
Development board package	DIP-30
Size	49.34*25.40(±0.2)mm
Antenna	IPEX
Frequency	2400 ~ 2483.5MHz
Operating temperature	-40°C ~ 85°C
Storage temperature	-40°C ~ 125°C , < 90%RH
Power supply	Support voltage 3.3V or 5V, supply current ≥500mA
Interface	Audio Codec、USB2.0、SDU、SD/MMC(SDH)、SPI、UART、I2C、I2S、PWM、GPDAC、GPADC、ACOMP and GPIO etc.
IO	18
UART rate	Default 115200 bps
Security	WPS/WEP/WPA/WPA2/WPA3
Flash	4MByte

2.1. Power selection

Ai-M62-M2-I-Kit three power supply modes are supported:

- Type-C interface power supply (recommend)
- 5V and GND pin header power supply
- 3V3 and GND pin header power supply

2.2. Static electricity requirement

Ai-M62-M2-I-Kit is an electrostatic sensitive device. Therefore, you need to take special precautions when carrying it.



Figure 2 ESD preventive measures

2.3. Electrical characteristic

Table 2 Electrical characteristics table

Parameters	Conditio	Min.	Typical value	Max.	Unit
Voltage	VDD	4.5	5	5.3	V
Voltage Supply	VDD	2.97	3.3	3.6	V
I/O	VIL	-	-	0.3*VDDIO	V
	VIH	-	0.7*VDDIO	-	V
	VOL	-	-	0.1*VDDIO	V
	VOH	-	-	0.9*VDDIO	V
	IMAX	-	-	-	15

2.4. Wi-Fi RF Performance

Table 3 Wi-Fi RF Performance Table

Description	Typical value			Unit
Frequency range	2400 ~ 2483.5MHz			MHz
Output power				
Mode	Min.	Typical	Max.	Unit
11ax Mode HE40, PA output power	-	16	-	dBm
11ax Mode HE20, PA output power	-	17	-	dBm
11n Mode HT40, PA output power	-	19	-	dBm
11n Mode HT20, PA output power	-	19	-	dBm
11g Mode, PA output power	-	19	-	dBm
11b Mode, PA output power	-	22	-	dBm
Receive Sensitivity				
Mode	Min.	Typical value	Max.	Unit
11b, 1 Mbps	-	-98	-	dBm
11b, 11Mbps	-	-90	-	dBm
11g, 6 Mbps	-	-93	-	dBm
11g, 54 Mbps	-	-76	-	dBm
11n, HT20 (MCS7)	-	-73	-	dBm
11ax, HE20 (MCS9)	-	-70	-	dBm
11ax, HE40 (MCS9)	-	-67	-	dBm

2.5. BLE RF Performance

Table 4 BLE RF performance table

Description	Typical value			Unit
Frequency range	2400 - 2483.5			MHz
Output Power				
Rate Mode	Min.	Typical value	Max.	Unit
1Mbps	-	10	15	dBm
2Mbps	-	10	15	dBm
Receive Sensitivity				
Rate Mode	Min.	Typical value	Max.	Unit
1Mbps sensitivity@30.8%PER	-	-99	-	dBm
2Mbps sensitivity@30.8%PER	-	-97	-	dBm

2.6. Power consumption

The following power consumption data are based on a 3.3V power supply, 25°C ambient temperature, and measured using an internal voltage regulator.

- All measurements are made at the antenna interface with a filter.
- All transmission data are based on 100% duty cycle in continuous transmission mode.

Table 5 Power consumption table

Mode	Min.	AVG	Max.	Unit
Tx 802.11b, 11Mbps, POUT=+22dBm	-	442	-	mA
Tx 802.11g, 54Mbps, POUT =+19dBm	-	296	-	mA
Tx 802.11n, MCS7, POUT =+19dBm	-	301	-	mA
Tx 802.11ax, MCS9, POUT =+17dBm	-	269	-	mA
Rx 802.11b, packet length 1024 byte	-	59	-	mA
Rx 802.11g, packet length 1024 byte	-	59	-	mA
Rx 802.11n, packet length 1024 byte	-	59	-	mA
Rx 802.11ax, packet length 1024 byte	-	59	-	mA

3. Appearance Dimensions

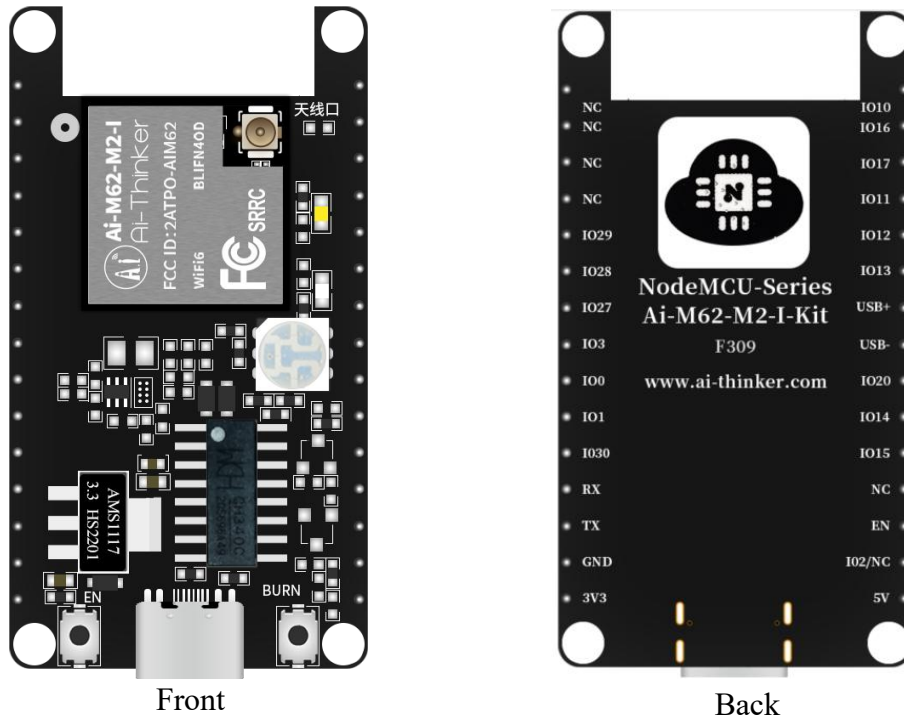

Figure 3 Appearance diagram (Rendering figure is for reference only,subject to physical objects)

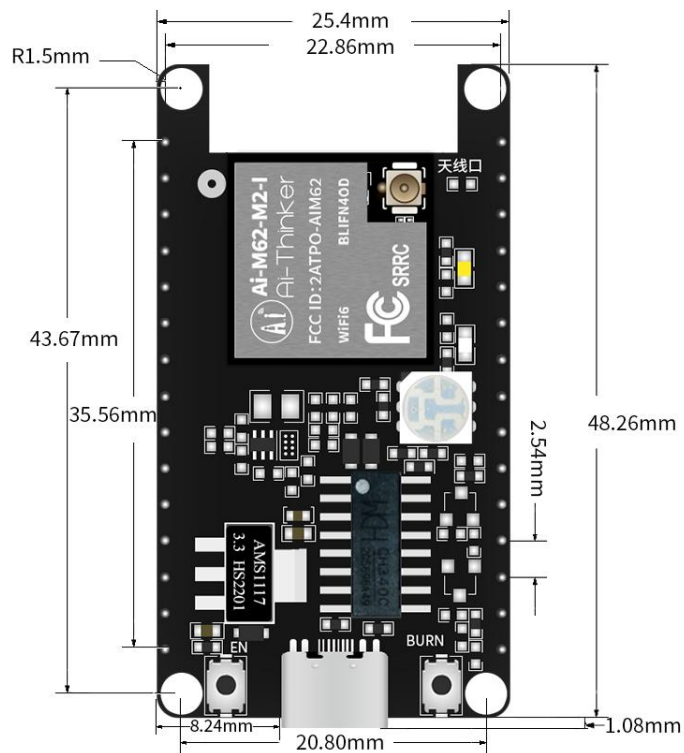

Figure 4 Dimension diagram

4. Description of the indicator light and the key button

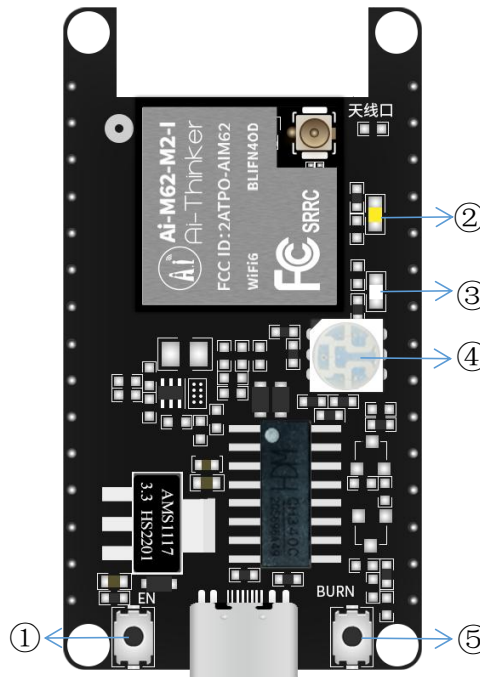

Figure 5 Ai-M62-32S-Kit indicator light and key position

Table 6 Ai-M62-32S-Kit indicator light and key position

①	RGB light (red light connect to IO1,green light connect IO30,blue light connect toIO0)
②	Reset button
③	White light (IO 29)
④	Warm light (IO 27)
⑤	Burning key. When burning, it is necessary to press the burn key and reset key successively, and then release the reset button and burn key successively

5. Pin definition

Ai-M62-M2-I-Kit connects with 30 interfaces, as shown in the schematic diagram of the pin, and the pin function definition table is the interface definition.

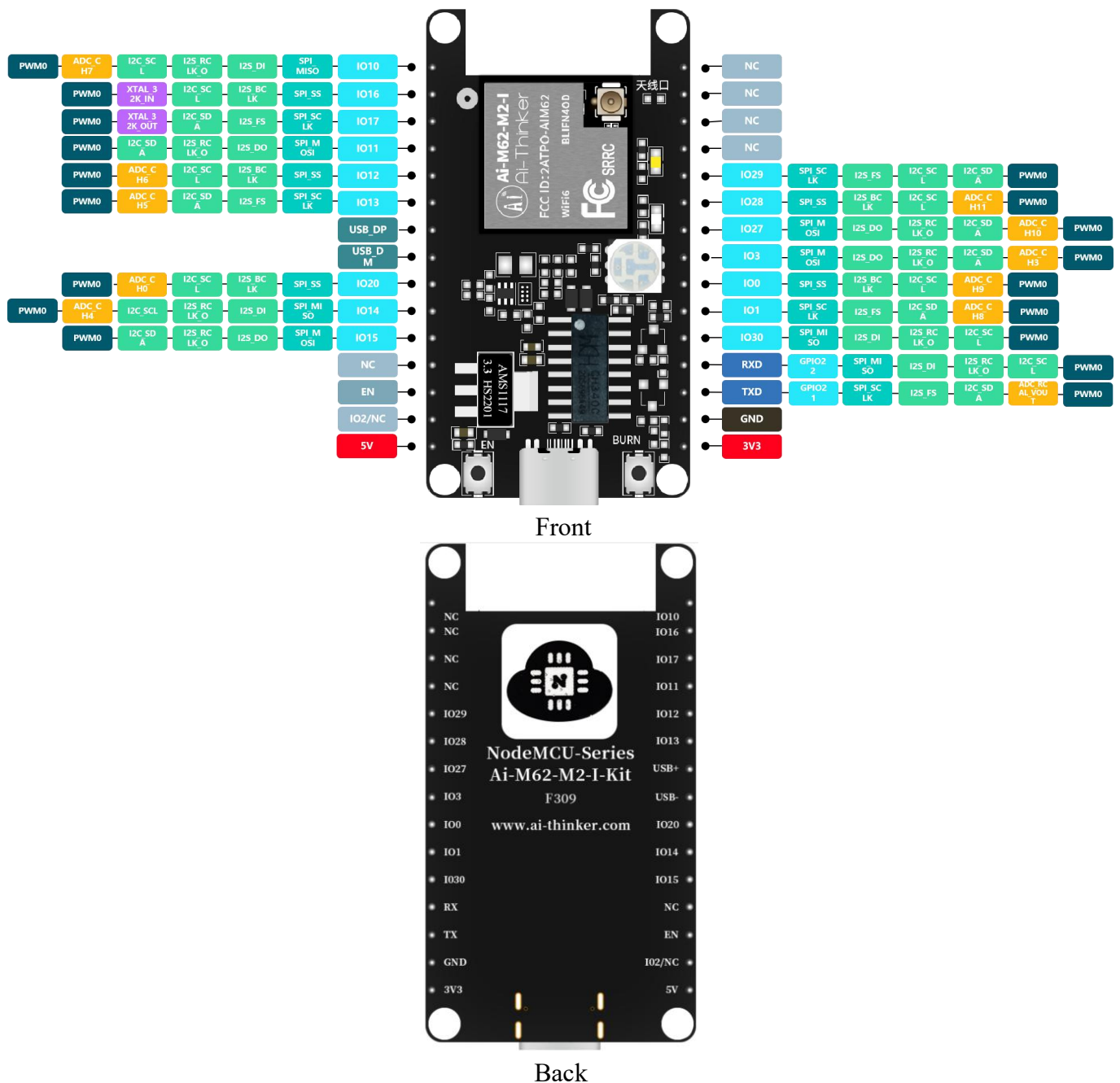

Figure 6 Schematic diagram of module pins

Table 7 Pin function definition table

No.	Name	Function
1	IO10	GPIO10/SPI_MISO/I2S_DI/I2S_RCLK_O/I2C_SCL/ADC_CH7/PWM0
2	IO16	Default available, the IO port is shared with the 32.768KHz crystal vibration output PIN foot inside the module. If the module of the internal patch 32.768KHz crystal vibration is customized, the IO is in the NC state.GPIO16/SPI_SS/I2S_BCLK/I2C_SCL/XTAL_32K_IN/PWM0
3	IO17	Default available, the IO port is shared with the 32.768KHz crystal vibration output PIN foot inside the module. If the module of the internal patch 32.768KHz crystal vibration is customized, the IO is in the NC state.GPIO17/SPI_SCLK/I2S_FS/I2C_SDA/XTAL_32K_OUT/PWM0
4	IO11	GPIO11/SPI_MOSI/I2S_DO/I2S_RCLK_O/I2C_SDA/PWM0
5	IO12	GPIO12/SPI_SS/I2S_BCLK/I2C_SCL/ADC_CH6/PWM0
6	IO13	GPIO13/SPI_SCLK/I2S_FS/I2C_SDA/ADC_CH5/PWM0
7	USB+	USB_DM
8	USB-	USB_DP
9	IO20	GPIO20/SPI_SS/I2S_BCLK/I2C_SCL/ADC_CH0/PWM0
10	IO14	GPIO14/SPI_MISO/I2S_DI/I2S_RCLK_O/I2C_SCL/ADC_CH4/PWM0
11	IO15	GPIO15/SPI_MOSI/I2S_DO/I2S_RCLK_O/I2C_SDA/PWM0
12	NC	NC
13	EN	Default as a chip enabled, high level effective
14	IO2/NC	Default NC, not available, if you want to use, please contact Ai-Thinker. If pin out, it support the Bootstrap/GPIO2/SPI_MISO/I2S_DI/I2S_RCLK_O/I2C_SCL/ADC_CH2/PWM0
15	5V	5V power supply
16	3V3	3.3Vpower supply
17	GND	Ground
18	TX	TXD/GPIO21/SPI_SCLK/I2S_FS/I2C_SDA/ADC_RCAL_VOUT/PWM0
19	RX	RXD/GPIO22/SPI_MISO/I2S_DI/I2S_RCLK_O/I2C_SCL/PWM0
20	IO30	GPIO30/SPI_MISO/I2S_DI/I2S_RCLK_O/I2C_SCL/PWM0
21	IO1	GPIO1/SPI_SCLK/I2S_FS/I2C_SDA/ADC_CH8/PWM0
22	IO0	GPIO0/SPI_SS/I2S_BCLK/I2C_SCL/ADC_CH9/PWM0

23	IO3	GPIO3/SPI_MOSI/I2S_DO/I2S_RCLK_O/I2C_SDA/ADC_CH3/PWM0
24	IO27	GPIO27/SPI_MOSI/I2S_DO/I2S_RCLK_O/I2C_SDA/ADC_CH10/PWM0
25	IO28	GPIO28/SPI_SS/I2S_BCLK/I2C_SCL/ADC_CH11/PWM0
26	IO29	GPIO29/SPI_SCLK/I2S_FS/I2C_SDA/PWM0
27	NC	NC
28	NC	NC
29	NC	NC
30	NC	NC

6. Schematic-diagram

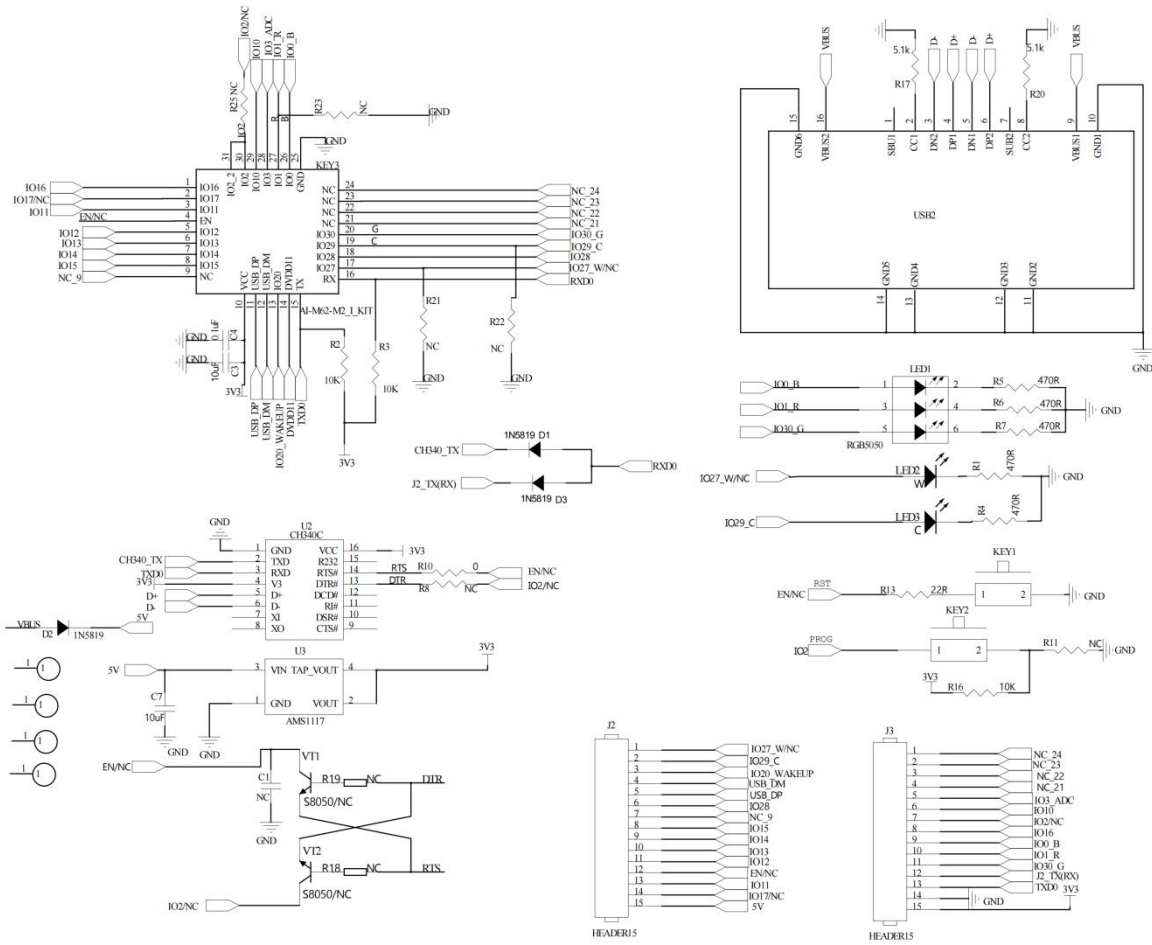

Figure 7 Module schematic

7. Product packing information

Table 8 Packing information table

Packing list	Manner of packing	MOQ (Electrostatic bag)	SPQ (sealing bag)
Ai-M62-M2-I-Kit	Bubble cotton + electrostatic bag	1pcs	20pcs

8. Contact us

[Ai-Thinker official website](#)

[Office forum](#)

[Develop DOCS](#)

[LinkedIn](#)

[Tmall shop](#)

[Taobao shop](#)

[Alibaba shop](#)

[Technical support email: support@aithinker.com](mailto:support@aithinker.com)

[Domestic business cooperation: sales@aithinker.com](mailto:sales@aithinker.com)

[Overseas business cooperation: overseas@aithinker.com](mailto:overseas@aithinker.com)

Company Address: Room 403,408-410, Block C, Huafeng Smart Innovation Port, Gushu 2nd Road, Xixiang, Baoan District, Shenzhen.

Tel: +86-0755-29162996



WeChat mini program



WeChat official account

Disclaimer and copyright notice

The information in this article, including the URL address for reference, is subject to change without notice.

The document is provided "as is" without any guarantee responsibility, including any guarantee for merchantability, suitability for a specific purpose, or non-infringement, and any guarantee mentioned elsewhere in any proposal, specification or sample. This document does not bear any responsibility, including the responsibility for infringement of any patent rights arising from the use of the information in this document. This document does not grant any license for the use of intellectual property rights in estoppel or other ways, whether express or implied.

The test data obtained in the article are all obtained from Ai-Thinker's laboratory tests, and the actual results may vary slightly.

All brand names, trademarks and registered trademarks mentioned in this article are the property of their respective owners, and it is hereby declared.

The final interpretation right belongs to Shenzhen Ai-Thinker Technology Co., Ltd.

Notice

Due to product version upgrades or other reasons, the contents of this manual may be changed.

Shenzhen Ai-Thinker Technology Co., Ltd. reserves the right to modify the contents of this manual without any notice or prompt.

This manual is only used as a guide. Shenzhen Ai-Thinker Technology Co., Ltd. makes every effort to provide accurate information in this manual. However, Shenzhen Ai-Thinker Technology Co., Ltd. does not guarantee that the contents of the manual are completely free of errors. All statements and information in this manual And the suggestion does not constitute any express or implied guarantee.